

## Getting started

Thank you for purchasing a *Logic Rail Technologies* product! Please familiarize yourself with all the instructions prior to installing this board. The *Block Animator/2* (versions BA/2, BA/2-IR, and BA/2-X) provides 3-color signaling for LED-based 3-light signals (individual red, yellow, and green LEDs) and searchlight-style signals constructed with either three individual LEDs (such as those from BLMA/Atlas, newer Tomar) wired with a common anode or a single, bipolar (red/green) LED (such as those from Oregon Rail Supply and Tomar's older ones). The *Block Animator/2* also includes our *TrueLens2* feature. This feature reproduces the "bounce" of the prototype searchlight signal mechanism which briefly flashes red when transitioning from yellow to green.

The *Block Animator/2* provides automatic operation of two 3-color block signals in a semi-prototypical way. Four sensors (photocells or infrared emitters and detectors) are used for bidirectional train detection; two are used for the Eastbound signal and two are used for the Westbound signal. The typical layout of the signals and sensors is illustrated below.

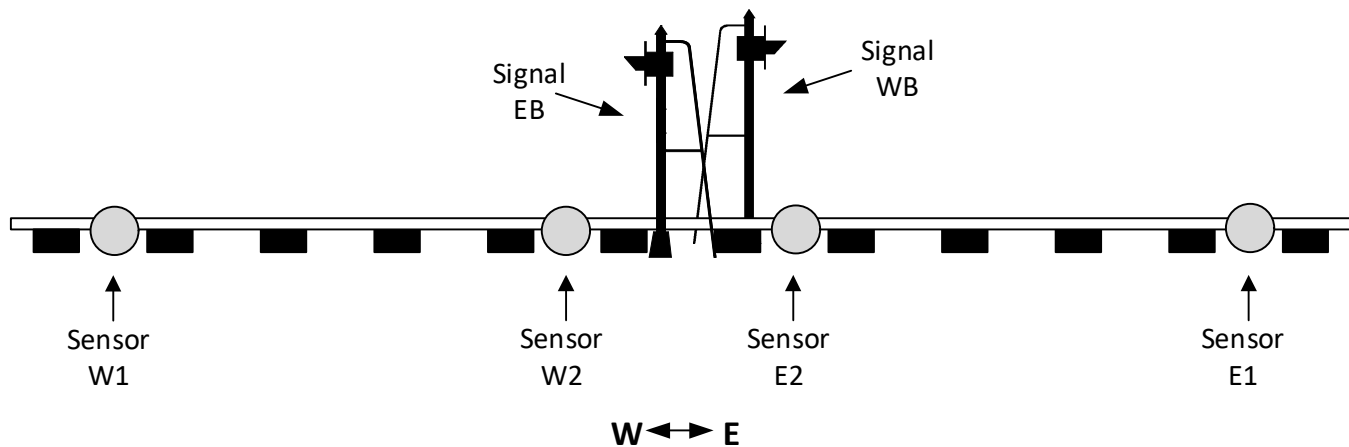

## What is different from the original version of the *Block Animator* (BA-1, BA-1-IR, BA-2 and BA-2-IR)?

- Signal outputs are turned on in sequence (Red → Yellow → Green), briefly, when power is first applied to the board. This gives you a quick test of the signals to make sure all the connections are correct and the signals work!
- The time delay between color changes is now adjustable from 1 to 127 seconds! You are no longer limited to choosing between one of two delay times.
- There are individual sensor status indicators on the circuit board. These not only help you when first setting up the board but are also active when in "operating" mode.
- The Flashing Yellow aspect has been added. When enabled the signal will transition from yellow to flashing yellow before returning to green. This simulates an Approach Medium indication.
- There is no need to swap chips on the board if you want to use a photocell, infrared between-the-rails, infrared across-the-rails, and external detectors. However, you will need to decide which sensor type (photocell or infrared), if any, you want at the time of purchase. Both sensor types are still available separately (#PCELL or #BTR-IR4) if you want to change types!
- The board is also offered without optical sensors (version BA/2-X) for use with other brands of external detectors.
- The infrared detection method has been improved and no longer has strict limits on the incoming voltage. **NOTE: the IR emitter wiring is different from the previous generation product!!! Please pay close attention to this.**
- We added another visual feature, Signal Fade, which fades individual aspects off and on when transitioning between the indications (clear, stop, approach). This feature can be enabled or disabled on the board.

## How does it work?

In the absence of any trains the two signals will be green. Now consider a train traveling eastbound. When sensor W1 is activated signal WB will change from green to red and will remain red as the train continues eastbound and subsequently activates sensor W2. When the train then activates sensor E2 signal EB will change from green to red. Once the train has totally cleared sensors W1 and W2 signal WB will change from red back to green. As the train continues eastbound towards sensor E1 signal EB will remain red. Once the train has passed over sensor E1 and totally clears both it and sensor E2 signal EB will change to yellow; this mimics the behavior of the train entering the "next block." After a time delay (adjustable; see page 7) signal EB will change to green. Signal operation for a westbound train is similar with signal EB changing from green to red and back to green while signal WB changes from green to red to yellow and back to green.

You should make all of the connections to the **Block Animator/2** before applying power to it. You can mount the **Block Animator/2** anywhere it is convenient underneath your layout using the four mounting holes provided. The holes will accept #4 screws; do not enlarge the holes as damage to the circuit board can result and your warranty will be voided!

The **Block Animator/2** board has a set of 10 configuration switches on it. Each switch is briefly described below with more details later in these instructions.

Switch Name	Meaning when OFF/OPEN	Meaning when ON/CLOSED
SETUP	BA/2 is in normal operating mode	BA/2 is in sensor setup mode
TRUE LENS2	Signal does NOT flash red during the yellow to green transition	Signal briefly flashes red during the yellow to green transition
SIG EB	EB signal has 4 wires with individual green, yellow and red LEDs (3-light or searchlight)	EB signal is a 2 or 3 wire searchlight type constructed with a single red/green LED (bipolar)
SIG WB	WB signal has 4 wires with individual green, yellow and red LEDs (3-light or searchlight)	WB signal is a 2 or 3 wire searchlight type constructed with a single red/green LED (bipolar)
YEL HUE	Yellow hue for bipolar LEDs is more reddish	Yellow hue for bipolar LEDs is more greenish
APPRL	Approach Lighting is Disabled	Approach Lighting is Enabled
SEN TYPE	Sensors are photocells or external current detectors	Sensors are infrared
SEN POL	See text in the Sensor Modes section	See text in the Sensor Modes section
FLASH YEL	Flashing Yellow feature is Disabled	Flashing Yellow feature is Enabled

### Approach Lighting

The concept of Approach Lighting is quite simple. A signal remains dark (not illuminated) until a train approaches it (i.e. the block in advance of the signal is occupied). This has been primarily used in the western U.S. in remote locations where signal equipment operates on battery power. Having the signals unlit most of the time saves battery power as well as prolongs the life of the bulbs. The “rule” for illumination is simple: the signal shall be illuminated when the preceding block is occupied. The **Block Animator/2** supports this feature (when the APPRL switch is ON/CLOSED) and works as follows. Signal EB will be illuminated whenever an eastbound train activates sensor W1 or sensor W2. Note that if the eastbound train activates and then clears sensor W1 but after 35 seconds hasn’t activated sensor W2, then the **Block Animator/2** will assume the train has actually reversed direction and will turn the signal off. Similarly, signal EB will also be illuminated whenever a westbound train activates sensor W2 and will keep signal EB illuminated until sensor W1 is activated and then subsequently cleared. The same 35 second “timeout” mechanism is in effect for this direction of travel too. Signal WB will operate in a similar manner with respect to sensors E1 and E2. You can turn approach lighting on or off at any time. If you turn this feature OFF then the signals will be illuminated all the time!

### Searchlight Signals with Bipolar LEDs (older Tomar Industries, Oregon Rail Supply, etc)

To select a 2 or 3 lead searchlight signal on the **Block Animator/2** you must have the appropriate configuration switch (SIG EB or SIG WB) in the ON position as shown in Figure 1. The type of LED used in these model searchlight signals is commonly called a bipolar or tri-color LED. This LED has two elements inside of a single housing; one element is green and the other is red. There are two ways that these LEDs are internally wired. One has two leads and the other has three leads; the three-leaded variety is the most common. The **Block Animator/2** supports either one as shown in Figures 2a & 2b; these diagrams depict the wiring for the Eastbound signal head; wiring for the Westbound signal head is equivalent. You MUST use resistors with LED-based signals! Because the **Block Animator/2** provides +5V power to the LED we recommend a resistor value of 150 ohms. We have included six resistors with this product; you can use higher value resistors if you wish! With a three-leaded variety you can choose to use one resistor in the common path (as shown in Figure 2b) or you could choose to use one resistor in EACH of the color (i.e. G & R) connections (this is NOT illustrated). **NOTE: The YEL and CTR terminals are not used with this signal type!**

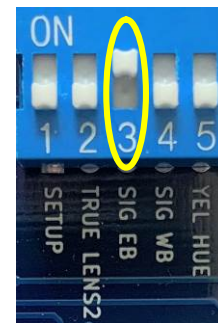

Figure 1 – selecting 2-lead or 3-lead searchlight signals (EB signal selection shown)

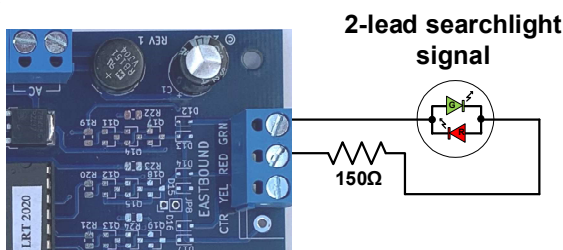

Figure 2a – two-lead bipolar (EB signal wiring shown)

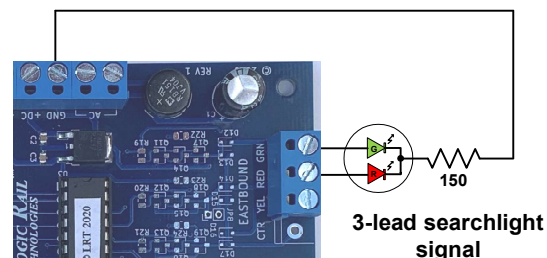

Figure 2b – three-lead bipolar (EB signal wiring shown)

You can adjust the yellow hue on these types of LED searchlight signals using the switch labeled YEL HUE on the circuit board. If the switch is in the ON position, as shown in Figure 3, then the yellow hue will be more greenish and less red; if the switch is in the OFF position then the yellow hue will be more reddish and less green. NOTE: this switch has no effect on searchlight signals constructed with individual green, yellow and red LEDs.

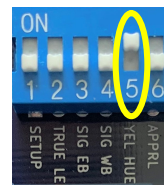

Figure 3 adjusting yellow hue

### Signals with 3 LEDs (Tomar Industries, Oregon Rail Supply, all BLMA, Atlas searchlights, etc)

To select signals using 3 individual LEDs (**this INCLUDES searchlight signals from BLMA/Atlas and the newer searchlight signals from Tomar**) you must have the appropriate configuration switch (SIG EB or SIG WB) in the OFF position as shown in Figure 4. The *Block Animator/2* directly controls 3-light LED signals wired in a common-anode (the anode is the positive side of the LED) arrangement. Virtually all brands of 3-light signals are wired this way. Two known exceptions are signals from Integrated Signal Systems which typically wire their signals in a common-cathode arrangement and the Atlas 3-light circular head (not searchlight) signals. We offer the *Block Animator/2* version BA/2-CC or BA/2-CC-IR for that type of signal wiring. You MUST use resistors with LED-based signals! Since the *Block Animator/2* provides +5V power to the LED we recommend a resistor value of 150 ohms. We have included six resistors with this product; you can use higher value resistors if you wish! We recommend using individual resistors in each of the LED cathode paths as illustrated in Figure 4. NOTE: The CTR terminal is not used with this signal type!



Figure 4 –selecting 3-LED signals (EB signal selection shown)

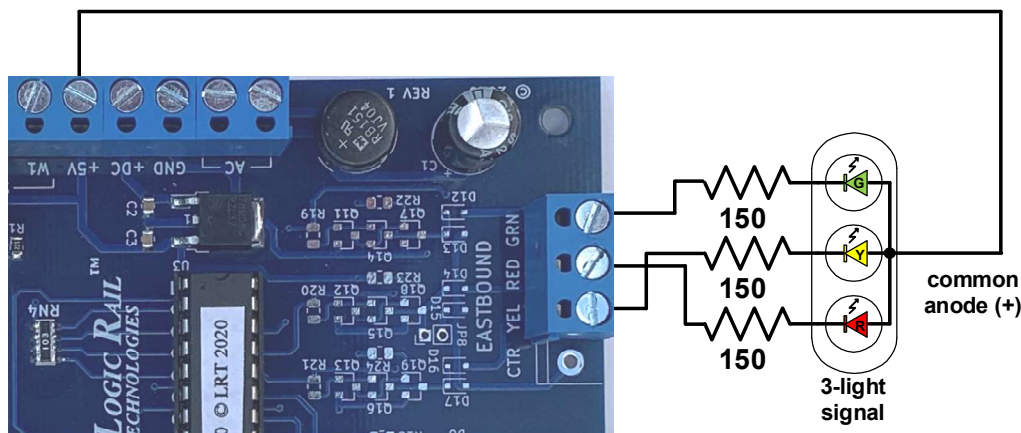
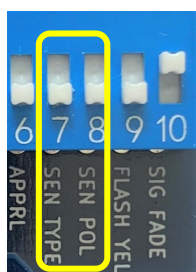

Figure 5 – 3-light signal (EB signal wiring shown)

### Sensor modes

The *Block Animator/2* supports four different sensor (detector) modes: photocell, between-the-rails infrared, across-the-rails infrared, and external detector. When you purchased this product it either came with a photocell, infrared components or neither (board only, for use with external detectors). The sensor mode is selected using the switches labeled SEN\_TYPE and SEN\_POL as depicted in the Table 1 below.



**Photocell**  
SEN TYPE – OFF  
SEN POL - OFF

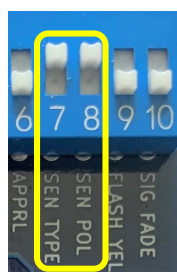

**Between-the-rails Infrared**  
SEN TYPE – ON  
SEN POL - ON

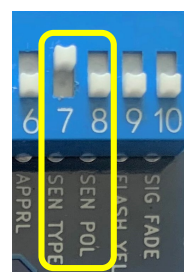

**Across-the-rails Infrared**  
SEN TYPE – ON  
SEN POL - OFF

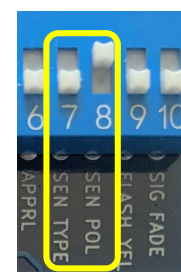

**External Detector**  
SEN TYPE – OFF  
SEN POL - ON

Table 1 – Sensor mode selection

## Using photocells for train detection

The photocells should be mounted between the rails in the general area where you will locate the signal. Drill a 9/64" hole through the ballast, roadbed, and sub-roadbed. For the smaller scales this drilling may end up hitting the ties. Take your time so you don't mangle them! Figure 6 illustrates the placement of a photocell in between the rails. Insert the leads of the photocell into the hole from the top of your layout. One of the photocell leads has a piece of insulation on it so be sure the two leads don't touch each other! If the leads do not

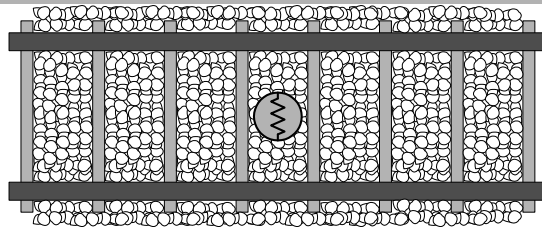

Figure 6 – photocell placement

protrude enough from the underside of your layout then it will be necessary to extend the leads; soldering wires to them is the most common method; make sure you insulate any connections you make to the photocell leads so that they don't short out. Once you have wired the photocells to the **Block Animator/2** and verified their operation you may wish to put a dab of white glue under the photocell to hold it in place; make sure you don't get glue on the top surface of the photocell as this may prevent it from operating properly. Figure 7 illustrates the photocell wiring; make sure you have the photocells in the correct order as shown at the top of page 1. Photocells do not have any polarity so you can connect either lead to the GND terminal and connect the remaining lead to the appropriate photocell input. The spacing between the outer photocells (W1 and E1) and inner photocells (E2 and W2) depends upon how long of a signal "block" you wish to define for each signal. However, keep in mind that there is a 35 second timeout that the **Block Animator/2** uses. This means that if it takes more than 35 seconds for a train to cover the nearest inner photocell after uncovering an outer photocell then the **Block Animator/2** will think the train has actually backed up and exited the block!

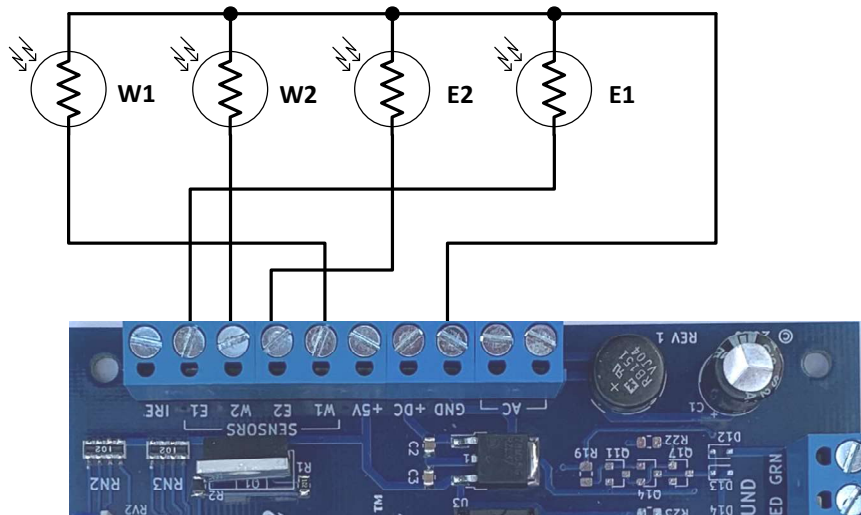

Figure 7 – Photocell wiring

Photocells require a light source above them to function properly. On most layouts the room lighting should be sufficient. However, if the photocells are located in an area that doesn't get much overhead lighting or if you have simulated "nighttime" operations then it will be necessary to locate light sources on the layout near the photocells. Street lights and yard lights are common light sources. Locate the light sources slightly to the left or right of the photocells and not directly over them; this will allow the **Block Animator/2** to still properly detect a train that has stopped over any photocell with the gap between cars over a photocell.

## Photocell sensitivity setup

You can adjust the sensitivity of each photocell on the circuit board using a small slotted head screwdriver. Along one edge of the board are four potentiometers (or "pots") that are labeled "W1", "E2", "W2" or "E1". The **Block Animator/2** supports a SETUP mode to make this adjustment process easier. To enable this mode, you must have the switch labeled SETUP in the ON/CLOSED position as shown in Figure 8. In this mode the signals will not change colors. The **Block Animator/2** circuit board contains four sensor status LEDs; one near each of the four adjustment pots. These LEDs will assist you in setting the photocell sensitivity. Now follow these steps:



Figure 8 - SETUP mode

1. Remove all obstacles that may be covering the photocells or blocking overhead light to them.
2. Insert the blade of the screwdriver (from the edge of the circuit board, not from the center of the board) into the adjustment pots, one at a time. Turn the screwdriver completely counter-clockwise (left) in all FOUR of the pots.
3. For the adjustment pot labeled W1 turn the screwdriver clockwise (right) until the red LED near the pot just lights up. Then turn the screwdriver back counter-clockwise until that LED goes out.
4. Repeat step 3 for the three remaining pots with corresponding LEDs.

- Exit SETUP mode by putting the SETUP switch in the OFF/OPEN position (“operational” mode). The signals should now operate properly. It may be necessary to repeat this procedure if layout lighting conditions change significantly. **Note that the *Block Animator/2* will activate the sensor status LEDs when the associated sensor detects a train in “operational” mode; this is different from the previous generation *Block Animator!***

Turning the pots clockwise adjusts for brighter overhead lighting conditions while turning the pots counter-clockwise adjusts for dimmer overhead lighting.

### Using Between-the-rails Infrared

The IR components should be mounted between the rails. Drill two 11/64” holes, through the ballast, roadbed, and sub-roadbed. These holes should be located one tie apart (Figure 9a) and drilled at a slight angle from vertical (see Figure 9b). The benefit of mounting them at an angle is increased detection reliability in smaller scales or irregular bottoms on rolling stock. For the smaller scales this drilling may end up hitting the ties. Take your time so you do not mangle them! Insert the leads of one IR emitter (white and black wires) into one of the holes (it does not matter which one!) from the top of your layout. Repeat for the IR detector (blue and black wires). **The tops of the components should sit no higher than the top of the ties for optimal IR performance;** in some cases (e.g. false triggering) it may be necessary to locate the components a little below the ballast line. You can extend the leads with similar (or larger) wire. We recommend soldering and insulating these connections. We also recommend using terminal blocks/strips since you will have multiple DC and GND connections to make. Once you have wired the IR components and verified their operation you may wish to put a dab of white glue or silicone caulk where the wires exit the holes underneath the layout. This will help to hold the components in place; make sure you do not get any substance (e.g. ballast or glue) on the top surface of the IR components as this may prevent them from operating properly. In extreme cases where you may be getting interference from overhead lighting you can mount the IR detector in some plastic or metal tubing. You can also recess the IR detector slightly below the ties and roadbed.

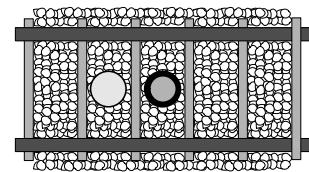

Figure 9a

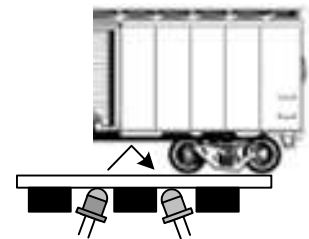

Figure 9b

### Using Across-the-rails Infrared

With this sensor mode and physical arrangement a train is detected when the infrared (IR) beam is broken by the train. The IR components should be located across the track as shown in Figure 10a and 10b; the distance between them has been tested up to 16 inches. The detectors (dark lens, blue and black wires) should be mounted with a slight downward angle in order to minimize the possibility of false triggering from visible light sources; this is illustrated in Figure 10a. We would also recommend that you angle the emitters and detectors across the track as shown in Figure 10b. This will minimize false “clear” situations due to the space between rolling stock. You can bend the IR emitter and detector components IF you are VERY careful and, preferably, use a pair of “smooth jaw” (no teeth/serration) pliers!! Make the bend on the IR component NO CLOSER than 0.5” from the tip. You don’t want to pierce the insulated heat shrink tubing and potentially cause a short.

In the event the leads do not reach the circuit board you can extend them with similar (or larger) wire. We recommend soldering these connections or using terminal blocks/strips especially when you have multiple connections to make.

Aligning the IR components for reliable detection might be a bit challenging. We recommend the use of a straight edge or ruler for initial “rough” alignment. You can tweak the final alignment once you are ready to test the circuit.

Since the IR components are located trackside, you will probably want to consider “hiding” them. There are numerous ways to do this such as using shrubbery, small equipment buildings or fixtures. We leave this exercise up to your imagination and creativity! We would strongly suggest that you get the circuitry working properly first, and then address the physical appearance.

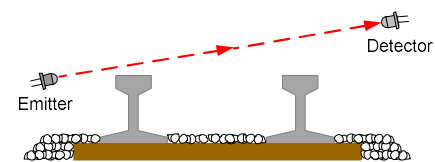

Figure 10a

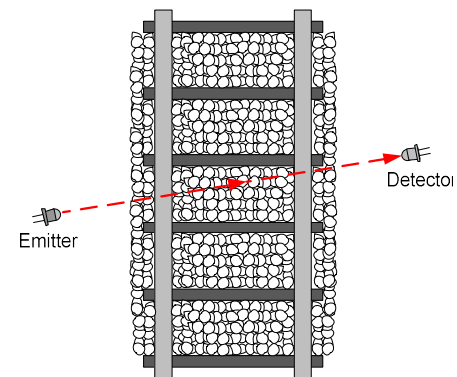

Figure 10b



Please note that the IR emitter wiring is **DIFFERENT** from the previous generation *Block Animator*!

Figure 11 illustrates the wiring for ONE set of IR components (shown for sensor location “W1”). REPLICATE the same wiring for the three remaining sensor inputs! Four 68 ohm ¼ watt resistors (Blue-Gray-Black color bands) are included with the *Block Animator/2*. **NOTE: The four adjustment pots have NO affect when using either infrared sensor mode!** When properly wired the emitters will have a very faint red glow. You can “see” the infrared light using your digital camera or smartphone camera! **For safety reasons do NOT point the IR emitter directly into your eye or stare at the IR emitter!!!**

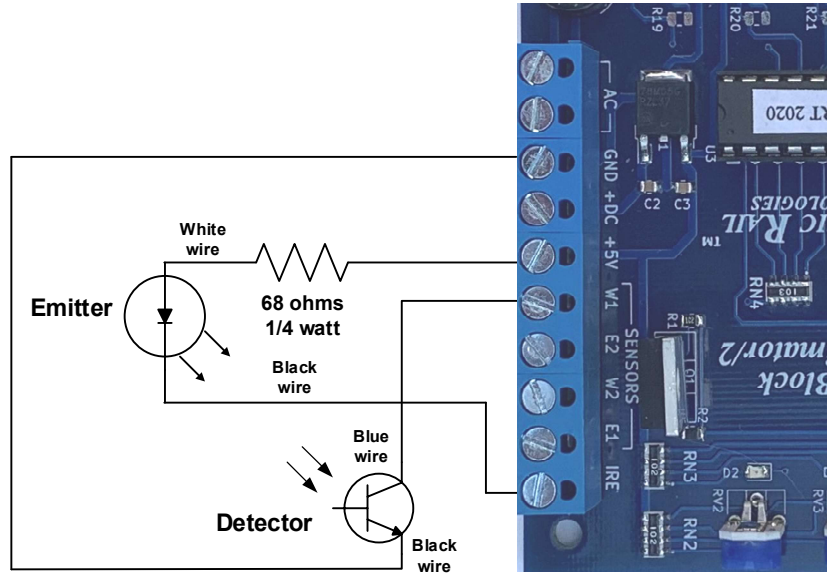

Figure 11 – IR component wiring  
(W1 input shown; replicate for E2, W2 and E1 inputs respectively)

**Using an external detector**

Use this sensor mode if you’d prefer to use a different type of detector such as an NCE BD20 current sensing detector. Any brand of detector should work provided that its output is an open collector, “active low” polarity, which means that when a train is detected the output is pulled to ground. When no train is sensed the detector output is an open circuit or “floating.” You will need 3 detection blocks or zones. Figure 12 shows how they would be partitioned.

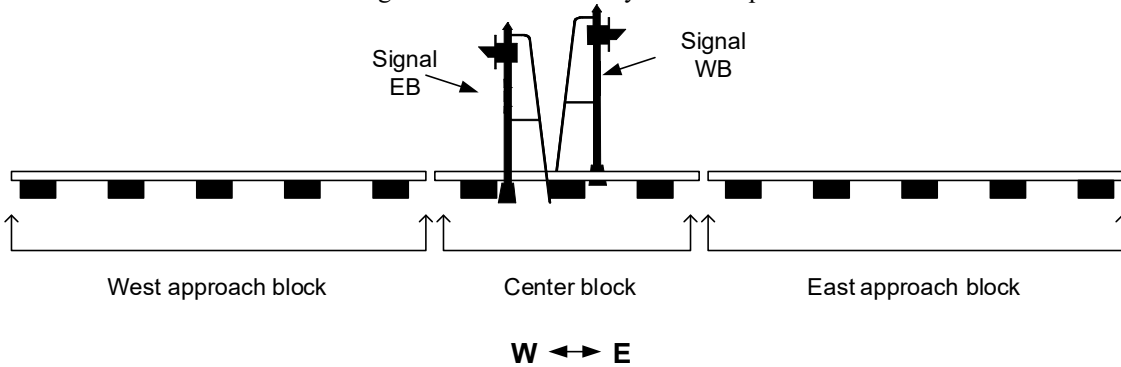

Figure 12 – External detector block/zone partitioning

Figure 13 shows how simple it is to connect the BD20 block detectors to the *Block Animator/2*.

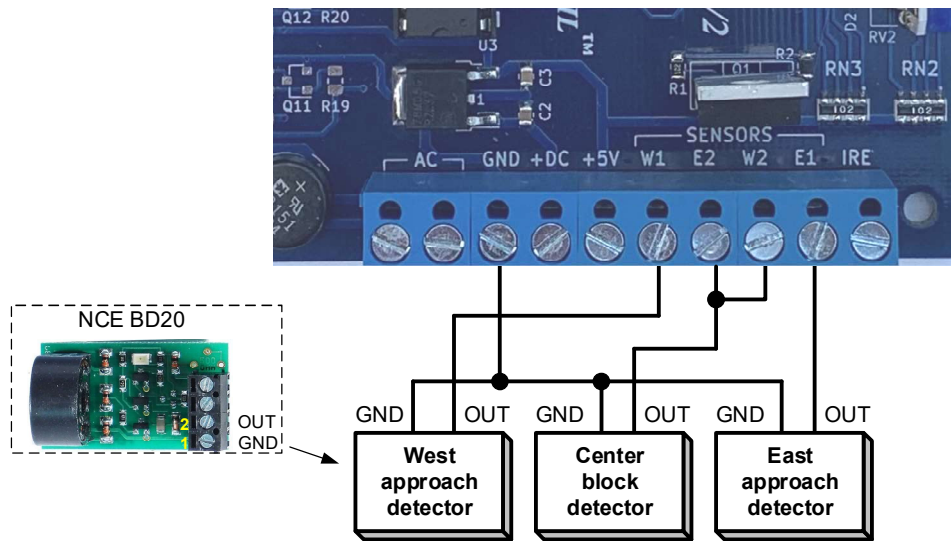

Figure 13 – External detector wiring (NCE BD20 shown)

### Signal color change delay

The signal color change delay be adjusted between approximately 1 and 127 seconds. This delay time affects the transition from yellow to green. If flashing yellow is enabled then the yellow to flashing yellow and flashing yellow to green transitions will have the same delay. The delay time is adjusted using a flat blade screwdriver inserted into the “pot” labeled “DELAY” on the circuit board. If you rotate it fully to the left you’ll get the minimum time delay. Rotating it fully to the right will give you the maximum time delay. Set the delay based on your own personal preference. On smaller layouts you may wish to have a shorter delay so that a looping train does not run into a red or yellow signal it just caused itself! You can change the delay time as you wish even when the power to the *Block Animator/2* is on.



Figure 14 – time delay

### Visual Effects (True Lens2, Flashing Yellow, Signal Fade)

The *Block Animator/2* not only retains the True Lens2 feature from the previous generation product but also introduces Flashing Yellow and Signal Fade effects.

**True Lens2** reproduces the “bounce” of the prototype searchlight signal mechanism which briefly flashes red when transitioning from the aspect from yellow to green. True Lens2 is enabled by having switch #2 in the ON/CLOSED position as shown in Figure 8. NOTE: this feature is enabled independently of the SIG EB and SIG WB switches which simply indicate the physical wiring of the signal. It is up to you to determine if you want this visual enabled or disabled.



**Flashing Yellow** adds another indication, Approach Medium, to the signal sequencing. When enabled (switch #9 in the ON/CLOSED position) the signals will sequence from red → yellow → flashing yellow → green.



**Signal Fade** reproduces the behavior of older prototype signals which used bulbs. As the indications change the aspects (colors) will fade off and on. To enable this feature switch #10 must be in the ON/CLOSED position.



### Power

The *Block Animator/2* accepts AC or DC power (7 - 16V). Power consumption, including the signals, ranges from ~60 mA (photocell version) to ~225 mA (infrared version). If you are only using a single board then you can use the AC terminals to provide power as shown in Figure 15a. You can use the accessory terminals on your throttle/power pack. If you are using more than one *Block Animator/2* (for example, if you’re interlocking with turnout positions) then you should consider powering them all from a single DC source as shown in Figure 15b. Watch the polarity and make sure you know what is positive! Contact us if you are uncertain! **When power is first applied the signal outputs will turn on briefly in sequence (Red → Yellow → Green).**

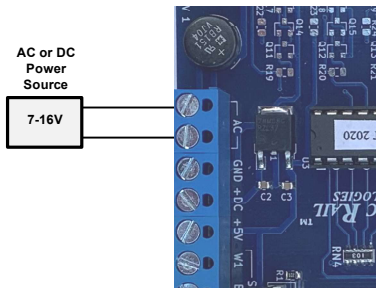

Figure 15a – AC power

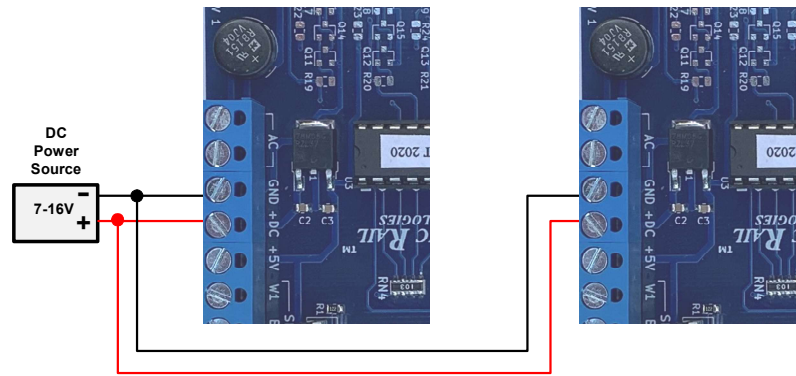

Figure 15b – DC power

## Other Applications

We have an instruction supplement and application notes on our website which cover topics such as interlocking a signal (i.e. force it to red) with the position of a turnout or controlling multi-headed signals.

## Alternate signal positioning

Rather than place the signals and sensors as shown on page 1 you may choose to locate the signals at the opposite ends of a long section of track as shown below. All wiring should follow what has been previously described. **Please note that with this usage of the *Block Animator/2* you CANNOT enable approach lighting; you MUST have the APPRL switch in the OFF/OPEN position in order to have proper signal behavior.**

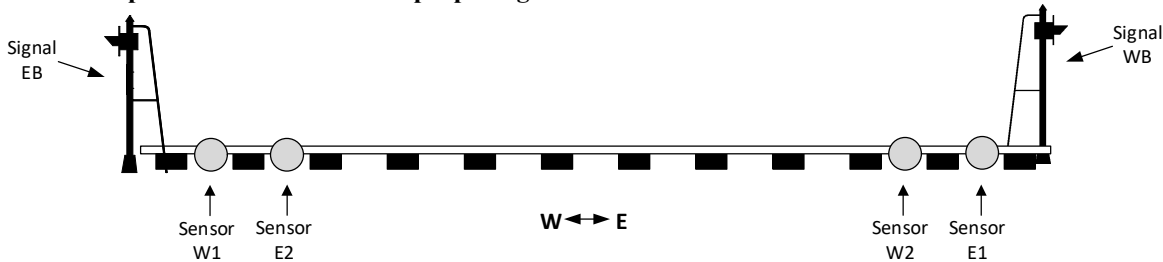

## Troubleshooting – photocell sensing

If your signals are not changing colors when the sensors are covered or stay red all the time you can perform the following tests. First, verify that you have the sensor mode configured correctly (see Table 1 on page 3). Second, revisit the photocell sensitivity adjustment process on page 4. A loose or missing wire connection on a photocell will cause its corresponding status LED to stay on all the time!

## Troubleshooting – Between-the-rails infrared sensing

If a signal is not changing colors when its associated sensors are activated or stays red all the time you can perform the following tests. First, **verify the sensor wiring previously described** and verify the glow of the IR emitters using a digital camera or smartphone camera. Also verify that you have the sensor mode configured correctly (see Table 1 on page 3). If the signal stays red all of the time then disconnect that signal's associated IR detectors blue wires. After two time delays the signal should return to green. If it does then there is a problem with one or both IR detectors. If your signal never changes from green then temporarily connect a wire between either of its detector input terminals and the GND terminal AND change the sensor mode to External Detector (see Table 1 on page 3). The signal should immediately change to red. If not, then the *Block Animator/2* board should be returned to us for test/repair. If the signal did change to red then disconnect the temporary wire. The signal should proceed through its delay and color changes. If so then the problem lies with the IR detector. Don't forget to configure the sensor mode properly again!

## Warranty

This product is warranted to be free from defects in materials or workmanship for a period of one year from the date of purchase. **Logic Rail Technologies** reserves the right to repair or replace a defective product. The product must be returned to **Logic Rail Technologies** in satisfactory condition. This warranty covers all defects incurred during normal use of this product. This warranty is void under the following conditions:

- 1) If damage to the product results from mishandling or abuse.
- 2) If the product has been altered in any way (e.g. soldering to the circuit board).
- 3) If the current or voltage limitations of the product have been exceeded.

Requests for warranty service must include a dated proof of purchase, a written description of the problem, and return shipping and handling (\$8.00 inside U.S./\$20.00 outside U.S. - U.S. funds only). Except as written above, no other warranty or guarantee, either expressed or implied by any other person, firm or corporation, applies to this product.

## Technical Support

We hope the preceding instructions sufficiently answer any questions you might have about the installation of this product. However, technical support is available should you need it. You can reach us via phone or email; see the top of page 1.